



Model 1800 CHAMP

*Optional "Swing Harp" cuts cheese horizontally for three dimensional portioning



GENERAL MACHINERY CORPORATION

P.O. Box 717
Sheboygan, WI 53082

Phone: 1-888-243-6622 or 1-920-458-2189 Fax: 1-920-458-8316
E-mail: Sales@genmac.com Web Site: www.genmac.com



MODEL 1800 CHAMP

Designed as the most rugged, compact, low cost cheese cutter of its kind on the market., the GMC 1800 CHAMP – a single stage cutter – has two directional portioning capability with a optional one or two wire swing harp.

Quick change cutting frames and platens adapt the GMC CHAMP to various portioning requirements. Open construction permits safe convenient loading. Toggle switch control raises, lowers, and holds feed platen at any desired level. Platen speed and pressure are regulated for maximum efficiency.

Even when cutting needs are small the GMC 1800 CHAMP can have a dynamic effect. Fine portioning enhances sales appeal. Less handling minimizes bacteria and improves quality. Fast cutting quickly frees an employee for other work. Maintenance is minimal

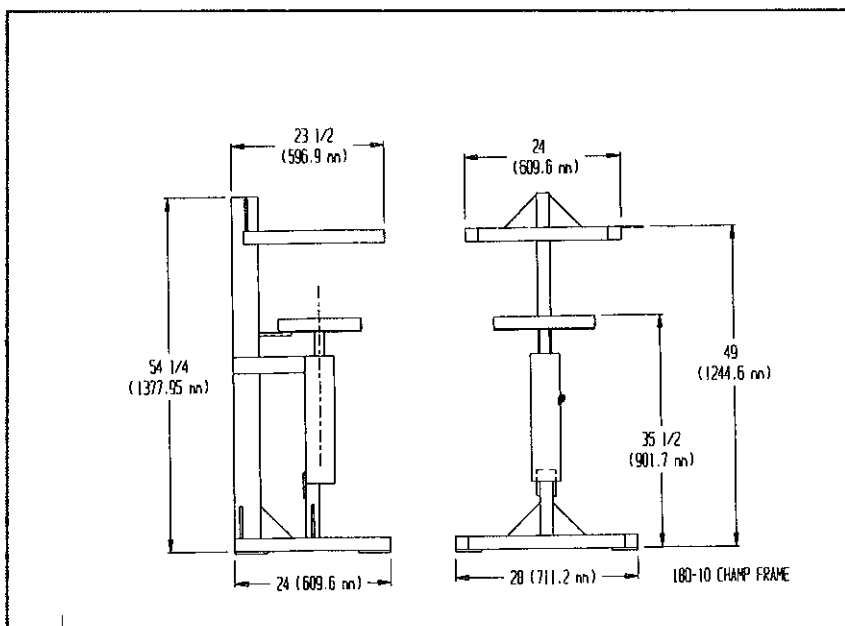

*GMC 1800
CHAMP Cheese
cutter for wire-
cuttable
products up to
7" x 11" x 14".
Pneumatic feed
80PSI, toggle
switch speed
and pressure
control, unitized
frame. Floor
space approx.
24"x 30".*